



Spare Parts

Wire Rope Electric Hoists T Series



Crane Components
Crane Kits
Electric Wire Rope Hoists
Electric Chain Hoists
Light Crane Systems
Spare Parts

Production of wire rope electric hoists
T series is discontinued from Podem
in 1998

50 YEARS
PODEM
2011

Contents

- 2 **Group 1** – Reducer for Electric Hoist with Lifting Speeds 8 m/min (T) and 12 m/min (T2) and Micro Lifting Speeds 8/1,4 and 12/1,4 m/min
- 4 **Group 2** – Body Kit with End-lifting Switch
- 6 **Group 3** – Clutch Set
- 7 **Group 4** – Rope Guide
- 8 **Group 5** – Drum
- 10 **Group 6** – Hook Set
- 12 **Group 7** – Lifting Motor – Single Speed
- 14 **Group 8** – Control Panel
- 16 **Group 9** – Electric Monorail Trolley
- 18 **Group 10** – Travel Motor $V = 20/6,5$ m/min
- 20 **Group 11** – Rope Load Limiter – Type BOT
- 21 **Descriptions of hoist type T, T2, T3**



Instructions for Using the Catalog

When using the catalogue identify the spare part you need of the appropriate figure and its catalog number, starting from the first column of the table.

The catalogue comprises parts which are manufactured wire rope electric hoists type T and T2 with capacity 500, 1000, 2000, 3200, 5000 and 8000 kg. For convenience, the catalogue is divided into 11 groups.

The position, the figures and the catalog number depend on the function of the part and sequence assembly. Established sequence will help you in the preparation of the request for spare parts and will serve you as a guide for repairing the hoist. The number of the figure is shown in the first column of each table. The name of the spare part is shown in the second column of each table, pay attention to the height of the lifting for each spare part. For spare parts applicable to all lifting height corresponding column is blank.

To avoid errors, every spare part must contain the following information:

Type, serial number and year of manufacture of the wire rope electric hoist.



Name and catalog number of the corresponding spare part.



Quantity of the necessary spare parts.

At the customer request, can be delivered whole groups, units of electric wire rope electric hoists.

– For example: Group 1 Pos. 37 Shaft 162041 etc.

All standard parts such as bolts, screws, nuts, and lock washers, cotter pins, etc.. marked in the catalog are provided to help servicing wire rope electric hoists; their quality and guaranty is not guaranteed by the producer.

Podemcrane AD reserves the right to change the Spare Parts catalog without notice.

Group 1 – Reducer for Electric Hoist with Lifting Speeds 8 m/min (T) and 12 m/min (T2) and Micro Lifting Speeds 8/1,4 and 12/1,4 m/min

Group 1										
Fig.	Pos.	Name	Quantity	Lifting height (m)	Cat. №					
					500 kg	1000 kg	2000 kg	3200 kg	5000 kg	8000 kg*
					Type T / T2	Type T / T2	Type T / T2	Type T / T2	Type T / T2	Type T / T2
1, 2	–	Reducer (set)	1	6, 18, 24	158001	141669	158025	158025	158033	158041
1, 2	–	Reducer (set)	1	9	141662	158013	158029	158029	158037	158041
1, 2	–	Reducer (set)	1	12	168293	168301	169321	169321	148863	149715
1	37	Shaft (input)	1	6, 18, 24	162041	162714	162212	162212	162177	–
1	37	Shaft (input)	1	9	162048	162908	162756	162239	162075	–
1	37	Shaft (input)	1	12	168327	168328	169172	169173	148148	–
1	37	Shaft (gear)	1	9	–	–	–	–	–	162334
1	37	Shaft (gear)	1	12	–	–	–	–	–	160803
1	11	Planetary gear wheel	2	6–24	162933	162933	162218	162218	162514	162340
1	14	Planetary gear wheel	3	6–24	162928	162928	162221	162221	162563	162358
1	33	Sun gear wheel	1	6–24	162779	162779	162102	162102	162021	–
1	36	Sun gear wheel	1	6–24	162712	162712	162099	162099	162520	147086
1	4	Vent stopper	1	6–24	505499	505499	505499	505499	505499	505499
1	29	Tapered stopper IV 1/4	2	6–24	581527	581527	581527	581527	581527	581527
2	43	Toothed sleeve	1	6–24	162934	162934	162224	162224	809252	162356

– *Hoists type "T" – for lifting capacity 8000 kg are with minimum lifting height H = 9 m.

– *Hoists type "T" – for lifting capacity 8000 kg, with H = 18, 24, 30, 36 m use reducer for lifting height H = 9 m.

– Fig. 1, Pos. 14 – for lifting capacity 500 kg and 1000 kg, please indicate the correct year of manufacture or wheel thickness.

– Fig. 1, Pos. 14 – for lifting capacity 500 kg have to order 2 (two) pieces of "Planetary gear wheel".

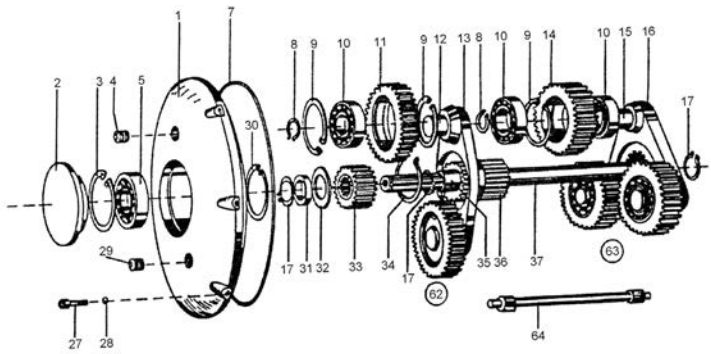

Fig. 1

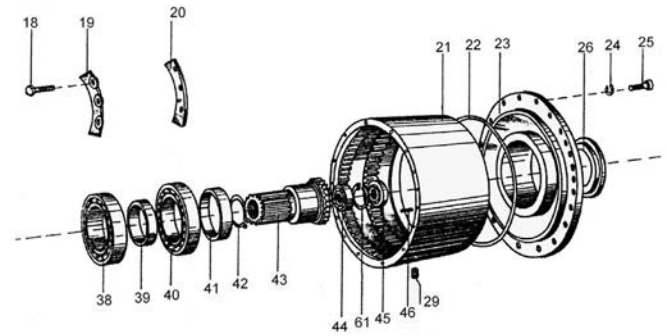

Fig. 2

- If you need second brake (mounted on the reducer), Podemcrane AD offers only brake without additional equipment.

Group 2 – Body Kit with End-lifting Switch

Group 2											
Fig.	Pos.	Name	Quantity	Lifting height (m)	Cat. №						
					500 kg	1000 kg	2000 kg	3200 kg	5000 kg	8000 kg	
					Type T / T2	Type T / T2	Type T / T2	Type T / T2	Type T / T2	Type T / T2	
3	14	Body	1	6	141701	180324	141711	141716	141721	–	
3	14	Body	1	9	141702	147237	143200	141717	141722	147181	
3	14	Body	1	12	141703	141708	141713	141718	141723	147183	
3	14	Body	1	18	147365	141709	143204	141719	141724	147188	
3	14	Body	1	24	141705	141710	143207	141720	141725	147200	
3	14	Body	1	30	T30126	T30136	T30146	T30156	–	149741	
3	14	Body	1	36	T30127	T30137	T30147	T30157	T30167	147193	
3a	–	Body	1	6	158053	158058	162483	149644	158073	–	
3a	–	Body	1	9	158054	158059	162760	162245	158074	158078	
3a	–	Body	1	12	158055	158060	162765	162308	158075	158079	
3a	–	Body	1	18	158056	158061	158066	158071	158076	147094	
3a	–	Body	1	24	158057	158062	158067	158072	162577	147095	
3a	–	Body	1	30	T30226	T30236	T30246	T30256	–	149740	
3a	–	Body	1	36	T30227	T30237	T30247	T30257	T30267	147120	
3	5	Ring	–	2	6–24	573283	573283	573283	573283	573283	573283
3	6	Bolt	M 6 x 25	2	6–24	222029	222029	222029	222029	222029	222029
3	7	Bar	–	1	6	143225	143356	158774	159819	158806	–
3	7	Bar	–	1	9	143232	147050	158777	159750	158808	158809
3	7	Bar	–	1	12	143233	143365	158778	159762	158807	149848
3	7	Bar	–	1	18	143344	143236	158775	159705	158802	149849
3	7	Bar	–	1	24	143347	143239	158779	159713	143264	147122
3	7	Bar	–	1	30	158775	158779	143264	143442	–	149850
3	7	Bar	–	1	36	159705	159713	143442	143633	158811	147132
3	8	Split pin	ø 2,5 x 14	2	6–24	211986	211986	211986	211986	211986	211986
3	9	Fork	Single lifting speed	1	6–24	–	–	159818	159818	158838	158760
3	9	Fork	Double lifting speed	1	6–24	148089	148089	159149	159149	149148	143267
3	10	Spring washer, H6	–	1	6–24	805599	805599	805599	805599	805599	805599
3	11	Nut	M 6 – 8	3	6–24	843150	843150	843150	843150	843150	843150

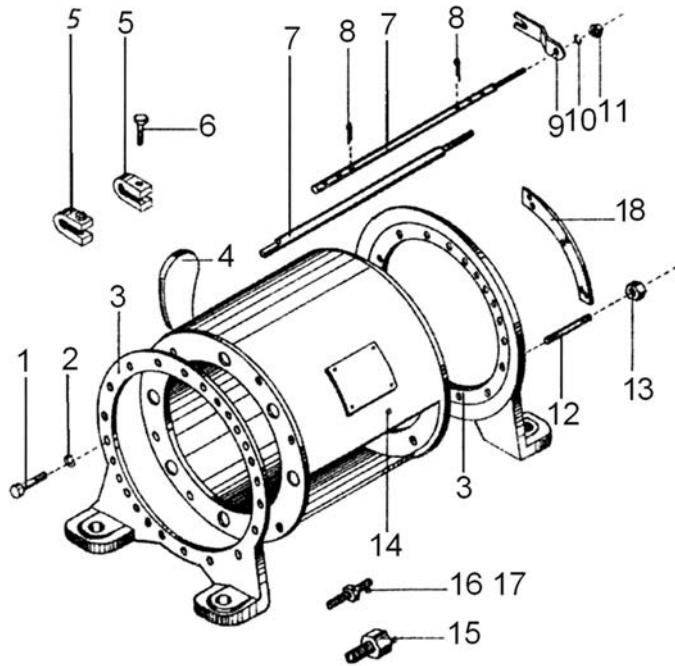

Fig. 3

- "Bar set" includes position 5, 6, 7, 8, 9, 10 and 11.
- When ordering "Bar set", please indicate "single" or "double" lifting speed.

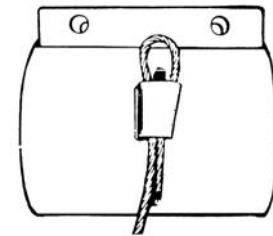

Fig. 3a

Group 3 – Clutch Set

Group 3						Cat. №					
Fig.	Pos.	Name	Quantity	Lifting height (m)	500 kg	1000 kg	2000 kg	3200 kg	5000 kg	8000 kg	
					Type T / T2	Type T / T2	Type T / T2	Type T / T2	Type T / T2	Type T / T2	
4	6, 7, 11	Clutch (set)	1	6, 9, 12	170100	170086	170087	170088	170089	170090	
4	6, 7, 11	Clutch (set)	1+1	18, 24	170100 + 170098	170086 + 170091	170087 + 170092	170088 + 170093	170089 + 170094	170090 + 170095	
4	7	Elastic body	1	6, 9, 12	170099	170076	170077	170078	170079	170080	
4	7	Elastic body	2	18, 24	170099	170076	170077	170078	170079	170080	

Subgroup — Elastic body										
–	–	Width of elastic body (B)	–	–	26 mm	30 mm	30 mm	34 mm	40 mm	44 mm

№	a2 (mm)	a1 (mm)	D (mm)
170100, 170086	E _B 25	E _B 20	103
170098, 170091	E _B 20	E _B 20	103
170087, 170088	E _B 30	E _B 25	113
170092, 170093	E _B 25	E _B 25	113
170089	E _B 40	E _B 30	138
170094	E _B 30	E _B 30	138
170090	E _B 45	E _B 35	168
170095	E _B 35	E _B 35	168

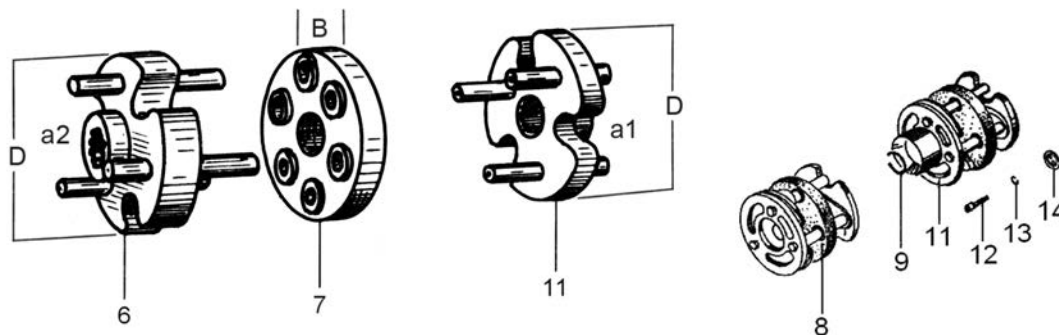

Fig. 4

Fig. 4a

– Clutch type "C" (with plastic components) have been used in hoists, manufactured from 1985 to 1998. Podemcrane AD doesn't offer this type of clutches.

Group 4 – Rope Guide

Group 4						Cat. Nº					
Fig.	Pos.	Name	Quantity	Lifting height (m)	500 kg	1000 kg	2000 kg	3200 kg	5000 kg	8000 kg	
					Type T / T2	Type T / T2	Type T / T2	Type T / T2	Type T / T2	Type T / T2	
5	1-7	Rope guide set (04M)	1	6-24	202807	202808	202809	202810	202811	202812*	
5	1-7	Rope guide set (04M)	1	30-36	202930	202931	202934	202935	202939	202812	

- *Hoists type "T" – for lifting capacity 8000 kg are with minimum lifting height H = 9 m.

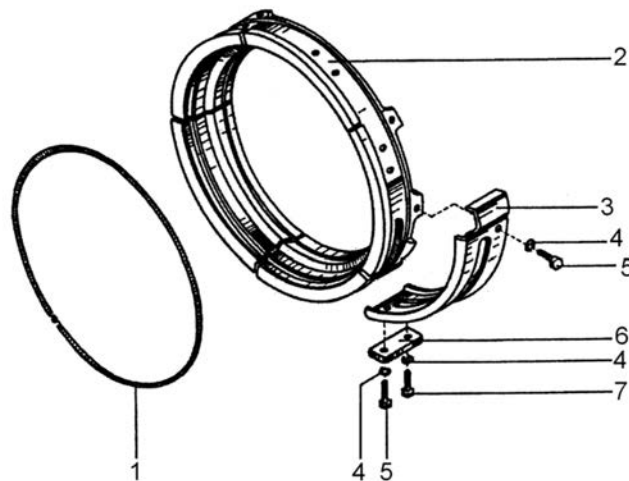

Nº	Thread step (mm)
202807, 202930	7,5
202808, 202931	9,42
202809, 202934	13
202810, 202935	15
202811, 202939	17,3
202812	20

Fig. 5

Group 5 – Drum

Group 5										
Fig.	Pos.	Name	Quantity	Lifting height (m)	Cat. №					
					500 kg	1000 kg	2000 kg	3200 kg	5000 kg	8000 kg
					Type T / T2	Type T / T2	Type T / T2	Type T / T2	Type T / T2	Type T / T2
6	1	Drum (05C)	1	6	204690	204694	204700	204703	204706	–
6	1	Drum (05C)	1	9	204691	204695	204701	204704	204707	204962
6	1	Drum (05C)	1	12	204692	204696	204702	204705	204708	204963
6	1	Drum (05C)	1	18	204774	204776	204778	204780	204767	204964
6	1	Drum (05C)	1	24	204775	204777	204779	204781	204768	204965
6	1	Drum (05C)	1	30	T30226.05C	T30236.05C	T30246.05C	T30256.05C	–	204966
6	1	Drum (05C)	1	36	T30227.05C	T30237.05C	T30247.05C	T30257.05C	T30267.05C	204967
6	2	Console (lantern)*	1	18–36	T0235.05.02.03	T0235.05.02.03	T0255.05.02.03	T0255.05.02.03	T0265.05.02.03	T0275.05.02.03
6	10	Intermediate shaft (T)	1	18	169108	169110	169353	169355	169991	149771
6	10	Intermediate shaft (T)	1	24	169109	169111	169354	169356	169992	149772
6	10	Intermediate shaft (T)	1	30	169353	169354	169992	T30256.05.02.02	–	149773
6	10	Intermediate shaft (T)	1	36	169357	169358	148834	148835	T30267.05.02.02	149774
6	10	Intermediate shaft (D)	1	18	257074	257076	257078	257080	257084	–
6	10	Intermediate shaft (D)	1	24	257075	257077	257079	257081	257085	–
6	10	Intermediate shaft (D)	1	30	257078	257079	257085	257086	–	–
6	10	Intermediate shaft (D)	1	36	257082	257083	257086	257087	257093	–
Fig.	Pos.	Name	Quantity	Lifting height (m)	Rope diameter					
					ø 6 mm	ø 8 mm	ø 11 mm	ø 13 mm	ø 16 mm	ø 18 mm
					№ 805734	№ 805735	№ 805730	№ 815705	№ 805732	№ 805403
6	3	Rope length	1	6	16 150	15 750	16 850	16 750	17 650	–
6	3	Rope length	1	9	22 150	21 750	22 950	22 750	23 650	24 950
6	3	Rope length	1	12	28 250	27 850	29 050	28 850	29 750	33 050
6	3	Rope length	1	18	40 150	39 750	40 980	40 780	41 680	42 980
6	3	Rope length	1	24	52 250	51 850	53 050	52 850	53 750	55 050
6	3	Rope length	1	30	–	–	–	–	–	66 850
6	3	Rope length	1	36	–	–	–	–	–	79 200

– Drum 05C is delivered with 3 (three) plates and 3 (three) screws.

– *The drum (05) with console (lantern) is out of manufacturing from 1983. Podemcrane AD doesn't offer this type of drum as spare part.

– When ordering "Intermediate shaft" please indicate its length.

– Intermediate shaft "T" is equipped with clutch type "T" till 1985. From 1985 to 1998 the Intermediate shaft is equipped with clutch type "C".

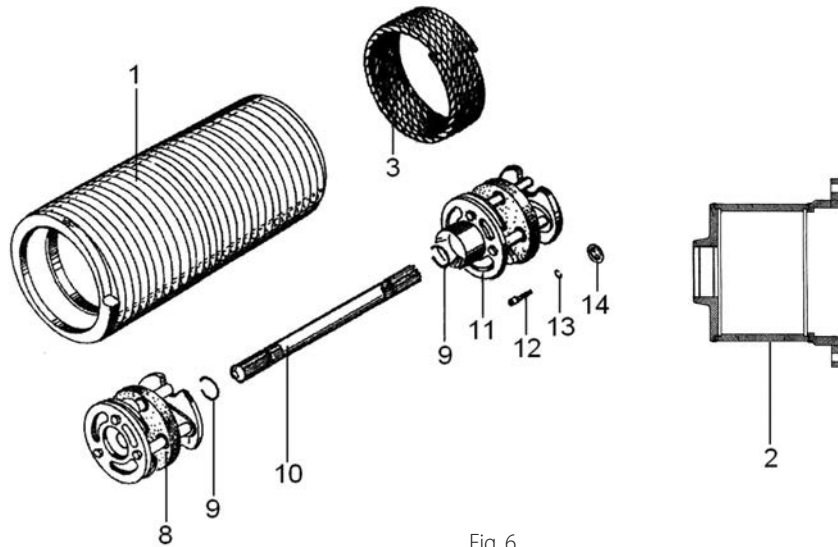

Fig. 6

Shaft "T" marked with Txxyz.05.02.02

	500 kg	1000 kg	2000 kg	3200 kg	5000 kg	8000 kg
18 m	308 mm	380 mm	381 mm	416 mm	387 mm	278 mm
24 m	468 mm	580 mm	581 mm	636 mm	597 mm	493 mm
30 m	381 mm	581 mm	597 mm	702 mm	–	708 mm
36 m	451 mm	671 mm	702 mm	877 mm	753 mm	918 mm

Shaft "C" marked with TxxyzД.29.06

	500 kg	1000 kg	2000 kg	3200 kg	5000 kg
18 m	278 mm	349 mm	350 mm	382 mm	350 mm
24 m	438 mm	549 mm	550 mm	602 mm	560 mm
30 m	350 mm	550 mm	560 mm	665 mm	–
36 m	420 mm	640 mm	665 mm	840 mm	–

Group 6 – Hook Set

Group 6										
Fig.	Pos.	Name	Quantity	Lifting height (m)	Cat. Nº					
					500 kg	1000 kg	2000 kg	3200 kg	5000 kg	8000 kg
					Type T / T2	Type T / T2	Type T / T2	Type T / T2	Type T / T2	Type T / T2
7	–	Hook (set)	1	6–24	816101	828295	828361	828364	828375	–
7	–	Hook (set)	1	9–36	–	–	–	–	–	828080
7	15	Tongue	1	6–24	836883	836883	836886	836885	836884	836884
7	15	Bolt	1	6–24	805429	805429	805215	805215	805215	805215
7	15	Spring	1	6–24	836891	836891	836890	836890	836889	836889
7	15	Nut	1	6–24	804824	804824	804824	804824	804824	804824

– We offering "Safety latch" by request. "Safety latch" set contains: safety latch, bolt spring and nut:

499-1836883	499-1836883	499-1836886	499-1836885	499-1836884	499-1836884
-------------	-------------	-------------	-------------	-------------	-------------

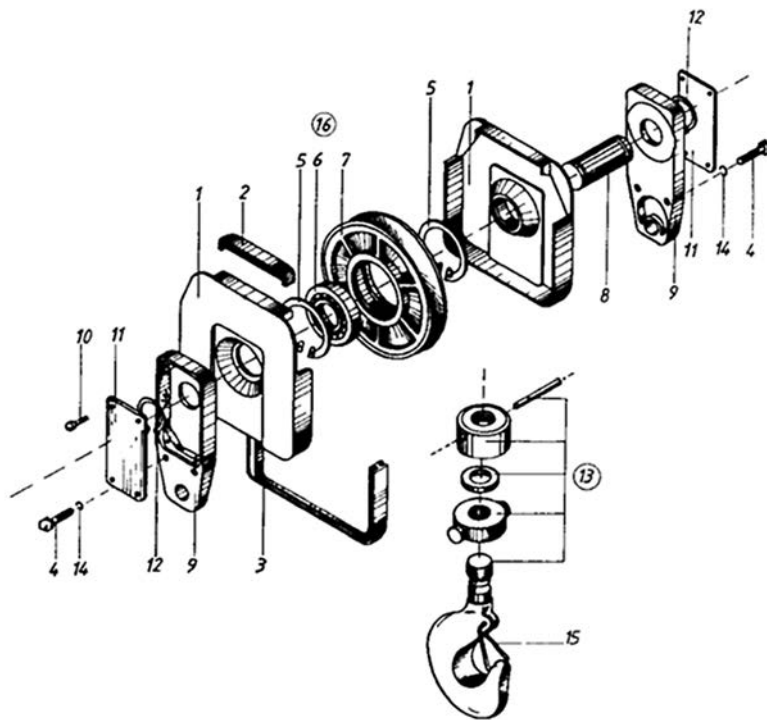

Fig. 7

Group 7 – Lifting Motor – Single Speed

Group 7										
Fig.	Pos.	Name	Quantity	Lifting height (m)	Cat. Nº					
					500 kg	1000 kg	2000 kg	3200 kg	5000 kg	8000 kg
					Type T	Type T	Type T	Type T	Type T	Type T
8,9	–	Motor Kg–1605–6	1	6–24	257989	–	–	–	–	–
8,9	–	Motor Kg–1608–6	1	6–24	–	582421	–	–	–	–
8,9	–	Motor Kg–2008–6	1	6–24	–	–	574536	–	–	–
8,9	–	Motor Kg–2011–6	1	6–24	–	–	–	575514	–	–
8,9	–	Motor Kg–2412–6	1	6–24	–	–	–	–	228607	–
8,9	–	Motor Kg–2714–6	1	9–36	–	–	–	–	–	257995
9	32	Rotor	1	6–24	280030	280019	280052	280042	280069	–
9	35	Rear shield	1	–	430136	430114	430153	430153	430188	623706
8	23	Front shield	1	–	–	430116	430155	430155	430190	–
9	39	Brake fan for Lifting motor – Single speed	1	–	345045	345045	280119	280119	280055	345301
9	39	Brake fan for Lifting motor – Double speed	1	–	345093	–	345094	345095	345097	345312
9	45	Grid	1	–	280001	280001	345108	430157	430192	504302
9	41	Fan housing	1	–	430112	430112	430150	430150	430186	582534
8	27	Limit switch	1	–	160694	160694	160695	160695	160695	160695
9	42	Rear adjusting nut	1	–	430036	430036	430152	430152	430061	345049

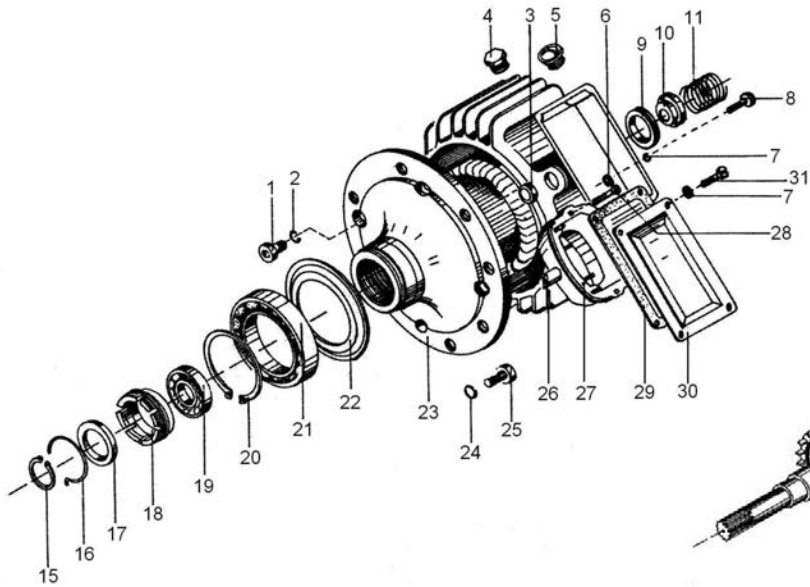

Fig. 8

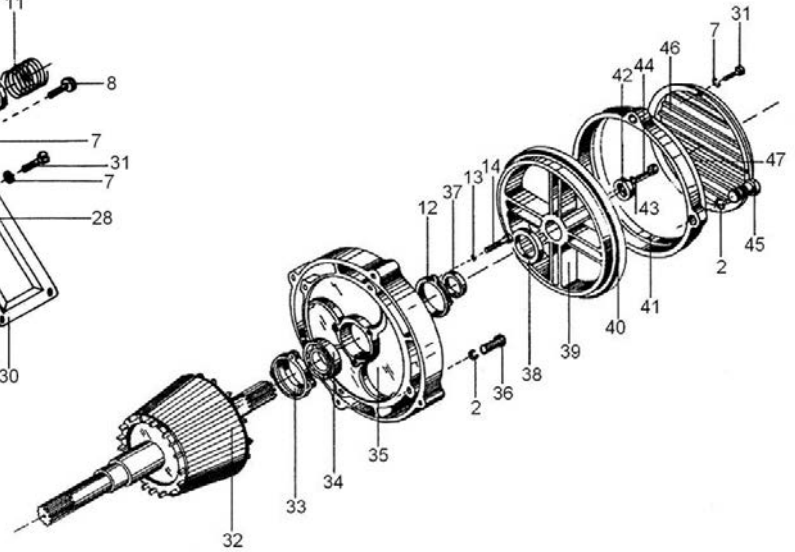

Fig. 9

Group 8 – Control Panel

Group 8										
Fig.	Pos.	Name	Quantity	V	Cat. Nº					
					500 kg	1000 kg	2000 kg	3200 kg	5000 kg	8000 kg
					Type T / T2	Type T / T2	Type T / T2	Type T / T2	Type T / T2	Type T / T2
10	–	Control panel (without control cable and control switch) for rope electric hoist with single lifting speed without trolley	1	380 – 42	171116	171116	192000	192000	256162	171265
10	–	Control panel (without control cable and control switch) for single speed rope electric hoist with single speed trolley	1	380 – 42	171157	171157	291997	291997	256188	171311
10	–	Control panel (without control cable and control switch) for double speed wire rope electric hoist without trolley	1	380 – 42	171132	171132	256163	256163	256164	171280
10	–	Control panel (without control cable and control switch) for double speed rope electric hoist with double speed trolley	1	380 – 42	171173	171173	256189	256189	256190	171335
10	13	Control cable	1	–	503919	503919	503919	503919	503919	503919
10	14	Control switch, 4-buttons, double speed	1	42	504758	504758	504758	504758	504758	504758
10	14	Control switch, 2-buttons, double speed	1	42	504761	504761	504761	504761	504761	504761

- Standard voltage is 380 V, for other supply voltages should indicate when ordering.
- Control voltage is 42 V, different is not available.
- The control panels are manufactured with the necessary equipment for installation with BOT (Rope Load Limiter).

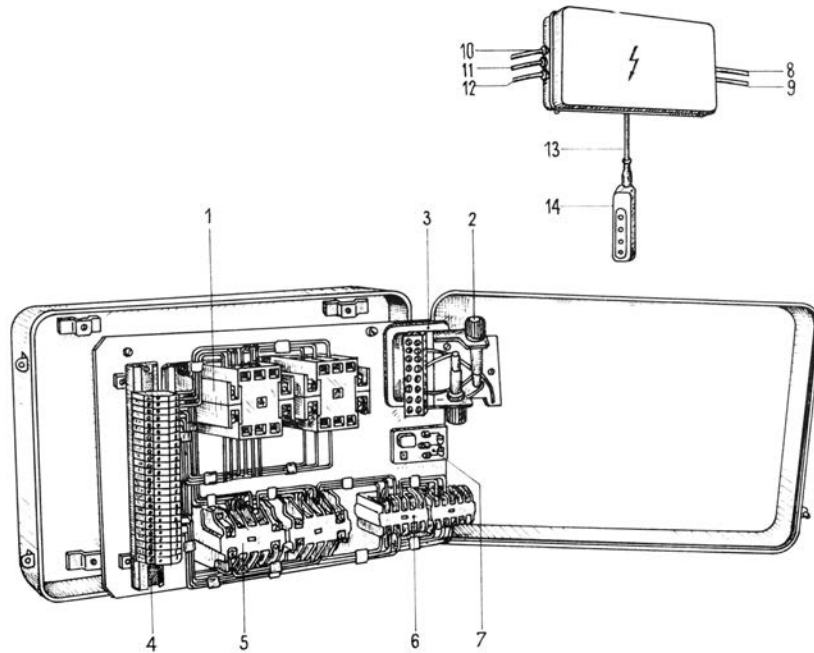

Fig. 10

- k – Power cable with length 10 m
- t – Open busbar

Group 9 – Electric Monorail Trolley

Group 9										
Fig.	Pos.	Name	Quantity	Lifting height (m)	Cat. №					
					500 kg	1000 kg	2000 kg	3200 kg	5000 kg	8000 kg
					Type T / T2	Type T / T2	Type T / T2	Type T / T2	Type T / T2	Type T / T2
11	–	Trolley (set, without motor)	1	6	T 1031	T 1031	T 1051	T 1051	T 1061	–
11	–	Trolley (set, without motor)	1	9, 12	T 1033	T 1033	T 1053	T 1053	T 1063	T 1061 (2 6p.)
12	–	Trolley (set, without motor)	2	18, 24	T 1031	T 1031	T 1051	T 1051	T 1051	T 1061
12	–	Trolley (set, without motor)	2	30, 36	T 1031	T 1031	T 1051	T 1051	T 1061	T 1061
11, 12	7	Driven travel wheel	2	6, 9, 12	252278	252278	252276	252276	252274	252274
11, 12	7	Driven travel wheel	4	18, 24	252278	252278	252276	252276	252274	252274
11, 12	11	Driving travel wheel	2	6, 9, 12	252290	252290	252288	252288	839699	839699
11, 12	11	Driving travel wheel	4	18, 24	252290	252290	252288	252288	839699	839699
11, 12	36	Gear block	1	6, 9, 12	192561	192561	148856	148856	242158	242158
11, 12	36	Gear block	2	18, 24	192561	192561	148856	148856	242158	242158
Wheel dimensions for monorail trolley										
					T1031/33	T1031/33	T1051/53	T1051/53	T1061/63	T1061/63
11, 12	7	Driven travel wheel	2	6, 9, 12	ø 120 mm	ø 120 mm	ø 175 mm	ø 175 mm	ø 210 mm	ø 210 mm
11, 12	7	Driven travel wheel	4	18, 24	ø 120 mm	ø 120 mm	ø 175 mm	ø 175 mm	ø 210 mm	ø 210 mm
11, 12	11	Driving travel wheel	2	6, 9, 12	ø 120 mm	ø 120 mm	ø 175 mm	ø 175 mm	ø 210 mm	ø 210 mm
11, 12	11	Driving travel wheel	4	18, 24	ø 120 mm	ø 120 mm	ø 175 mm	ø 175 mm	ø 210 mm	ø 210 mm

– Travel wheels – Pos. 7 and 11 are offered only with universal profile.

– Monorail trolley is offers only for profile till 150 mm.

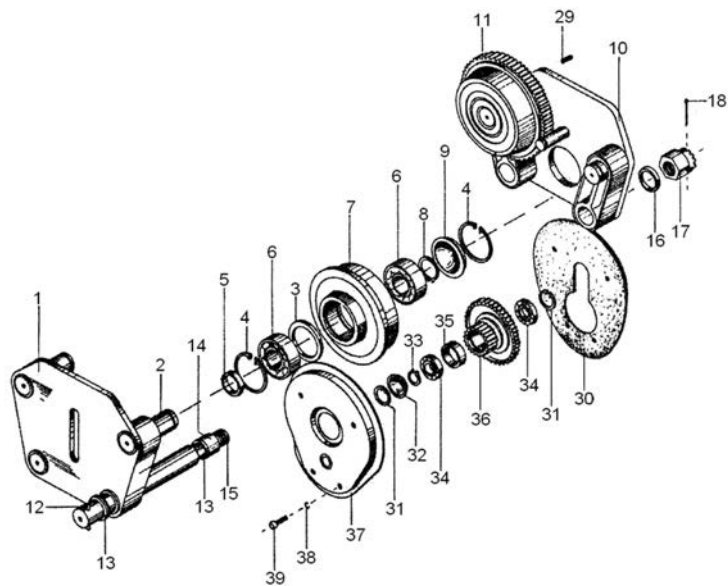

Fig. 11

- 6, 9, 12 m = Driving trolley

Gear block

	192561	148856	242158
d	40 mm	47 mm	47 mm
D	138 mm	139 mm	159 mm

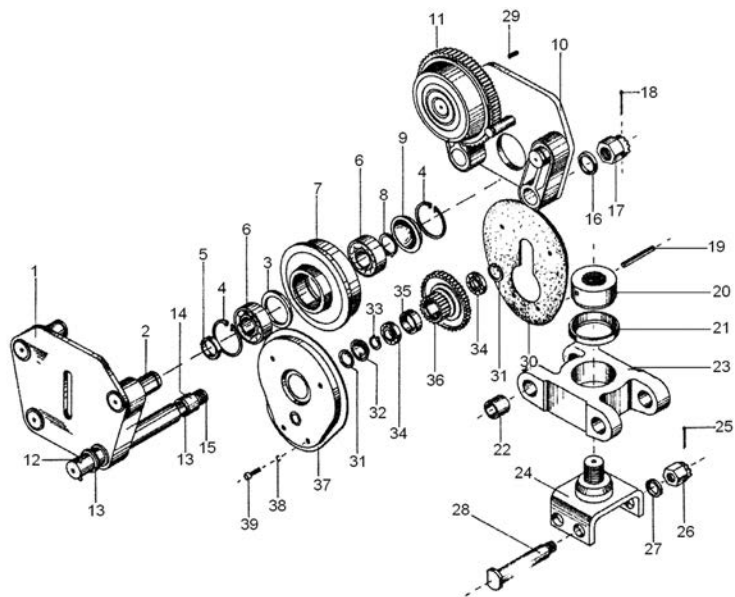

Fig. 12

- 18, 24 m = Driving trolley + Driven trolley

Group 10 – Travel Motor $V = 20/6,5$ m/min

Group 10										
Fig.	Pos.	Name	Quantity	Lifting height (m)	Cat. №					
					500 kg	1000 kg	2000 kg	3200 kg	5000 kg	8000 kg
					Type T / T2	Type T / T2	Type T / T2	Type T / T2	Type T / T2	Type T / T2
Subgroup 1 — Travel motor — Double speed with cylindrical rotor										
13	–	KT 80A–12/4–35 (0,08/0,25 kW)	1	6–24	503970	503970	–	–	–	–
–	–	– Affix ПК 1813	1	6–24	254459	254459	–	–	–	–
13	–	KT 80B–12/4–35 (0,12/0,37 kW)	1	6–24	–	–	503526	503526	503526	503526
–	–	– Affix ПК 3713	1	6–24	–	–	254452	254452	254452	254452
Subgroup 2 — Travel motor — Double speed with conical rotor										
14	–	KK 1405–12/4 (0,06/0,18 kW)	1	6–24	580453	580453	–	–	–	–
–	–	– Affix ПК 1813	1	6–24	254459	254459	–	–	–	–
14	–	KK 1407–12/4 (0,11/0,37 kW)	1	6–24	–	–	505614	505614	505614	505614
–	–	– Affix ПК 3713	1	6–24	–	–	254452	254452	254452	254452

- For achieving the speed 20/6,5 m/min every motor must be ordered with affix.
- It is desirable when ordering to indicate the motor power or lifting capacity of the hoist.

Subgroup 3 — Gear wheel pinion for travel motor — double speed 1400 rpm										
–	–	Gear wheel pinion	1	6-24	254497*	254497*	254495**	254495**	254495**	254495**

- *254497 marked with T 103113 01Г 03 02 is with Z = 16 teeth, module 1,5
- **254495 marked with T 106113 01A 03 02 is with Z = 19 teeth, module 1,5

Subgroup 4 — Gear wheel pinion for travel motor — single speed 1400 rpm										
–	–	Gear wheel pinion	1	6-24	192553*	192553*	148899**	148899**	148899**	148899**

- *192553 marked with T 1031 01Г 03 01 is with Z = 12 teeth, module 1,5
- **148899 marked with T 1051 01A 03 01 is with Z = 14 teeth, module 1,5

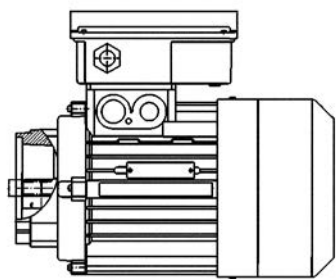

Fig. 13

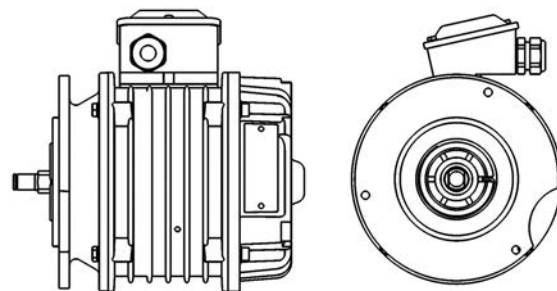
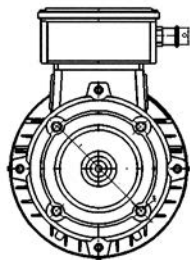

Fig. 14

Group 11 – Rope Load Limiter – Type BOT

Group 11						
Fig.	Pos.	Name	Quantity	Q (kN)	Rope diameter (d)	Cat. №
15	–	BOT 025	1	2,5	6...8	–
15	–	BOT050	1	5	6...8	829913
15	–	BOT 100	1	10	10...14	829914
15	–	BOT 160	1	16	9...14	829915
15	–	BOT 250	1	25	12...16	829916
15	–	BOT 400	1	40	14...18	829917
15	–	BOT 500	1	50	14...20	829918

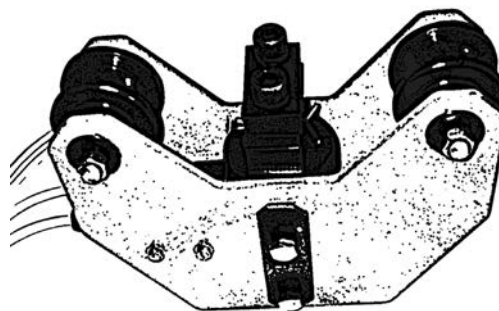

Fig. 15

Descriptions of hoist type T, T2, T3 (__TXXYZWMC)

T	__T	XX	Y	Z	W	M	(A)*	C
Lifting speed	Extras	Modifications	Load capacity reeving 2/1	Lifting height (m)	Trolley speed in meters per minute	Lifting motor double speed		Second lifting brake
T* 8 m/min	11T With secret key	01 For foot mounted	2 0,5 t ø 6	1 6	2 20 m/min without brake			*See the note on Fig. 1
T2* 12 m/min	12T With thermal protection	02 Without trolley	3 1 t ø 8	2 9	3 32 m/min with brake			
T3* 16 m/min	13T With secret key and thermal protection	08 With driven trolley	4 2 t ø 11	3 12	4 8 m/min with brake			
	42T With load limiter	09 With manually operated trolley	5 3,2 t ø 13	4 18	5 10 m/min with brake			
	43T With secret key and load limiter	10 With electric monorail trolley	6 5 t ø 16	5 24	6 20 m/min with brake			
	44T With thermal protection and load limiter	17 Reeving 1/1	7 8 t ø 18	6 30	7 12 m/min with brake			
	45T With secret key, thermal protection and load limiter	35 Foot mounted (Reeving 4/1)	8* 12,5 t ø 18	7 36	8 15 m/min with brake			
		39 Electric monorail trolley (Reeving 4/1)	9* 16 t ø 18		11 12/4 m/min with brake			
		44 Low Headroom 2/1, manually operated trolley			12 15/5 m/min with brake			
		45 Low Headroom 2/1, electric monorail trolley			13 20/6,5 m/min with brake			
		51 Foot mounted Reeving 2/2, the ropes are in one direction			14 32/10 m/min with brake			
		52 Foot mounted Reeving 2/2, the ropes are in the two directions						
		78 Low Headroom 4/1, with electric monorail trolley						

T, T2, T3 – Climatic environment if different from standard
T1 – Work under shed in dry and humid tropical climate
MP – Work according maritime certificate
C – Work in low aggressive chemical environment

8 – 12,5 t – reeving 3/1 (XX=01, 10) or 4/1 (XX=39)
9 – 16 t – reeving 4/1 (XX=35)

(A) – The letter A is meaningful only for the producer (T=MAC, T2=AMC)



Spare Parts

Wire Rope Electric Hoists
T Series

—
November 2015



Podemcrane AD
1 General Nikolov St., 5300 Gabrovo, Bulgaria
t +359 66 801 375, f +359 66 801 390
spare.parts@podem.bg
podem.bg

50 YEARS
PODEM
2011